

4

3

2

1

NOTES:

- A. ALL GRAVEL TO BE HAND LEVELLED
- B. PLACE WATER INTO TANK BEFORE POURING GRAVEL OR HAND LOAD.  
CARE MUST BE TAKEN WHEN INSTALLING GRAVEL TO NOT DAMAGE UNDERDRAINS
- C. BASE LAYER OF 1-1/2" x 3/4" CAN BE ADDED BELOW 1/2" X 3/4" IF ROOM ALLOWS

B

B

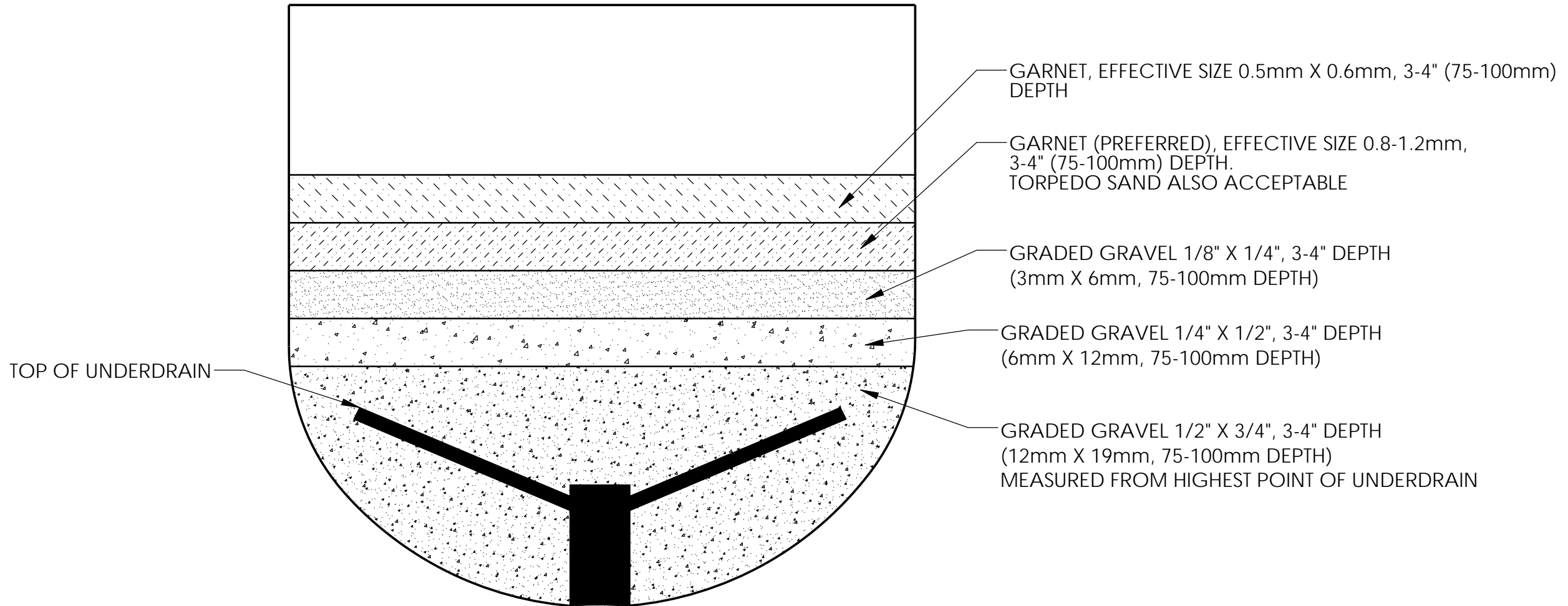

A

A

UNLESS OTHERWISE SPECIFIED, ALL DIMENSIONS ARE IN INCHES THIRD ANGLE PROJECTION  	<b>CONFIDENTIAL</b> <small>THIS DRAWING AND ALL INFORMATION CONCERNING IT IS CONFIDENTIAL, PROPRIETARY AND/OR A TRADE SECRET TO WATERPOLIS CORP. POSSESSION OF THE DRAWING CONSTITUTES AGREEMENT TO MAINTAIN THE DRAWING AND ALL INFORMATION CONCERNING IT AS CONFIDENTIAL, PROPRIETARY AND/OR TRADE SECRET TO WATERPOLIS CORP. NEITHER THE DRAWING NOR ANY INFORMATION CONCERNING IT MAY BE COPIED, EXHIBITED, OR FURNISHED TO OTHERS WITHOUT WRITTEN PERMISSION FROM WATERPOLIS CORP. THE DRAWING AND INFORMATION CONCERNING IT SHALL BE RETURNED ON REQUEST.</small> REV 01/09		GRAVEL PACK LAYER ASSEMBLY		
		DRAWN MM DATE APR-6-2019 WT lbs	ENG APVD	SIZE B SCALE NTS	DWG NO REV 01 SHEET SHEET 1 OF 1

4

3

2

1